



# Model 2810-005 Coefficient of Friction Testing Fixture

Equipment Reference M10-13933-EN Revision F

*The difference is measurable®*

## **Electromagnetic Compatibility**

Where applicable, this equipment is designed to comply with International Electromagnetic Compatibility (EMC) standards.

To ensure reproduction of this EMC performance, connect this equipment to a low impedance ground connection. Typical suitable connections are a ground spike or the steel frame of a building.

---

## **Proprietary Rights Notice**

This document and the information that it contains are the property of Illinois Tool Works Inc. (ITW). Rights to duplicate or otherwise copy this document and rights to disclose the document and the information that it contains to others and the right to use the information contained therein may be acquired only by written permission signed by a duly authorized officer of ITW.

---

## **Trademarks**

Instron<sup>®</sup> is a registered trademark of Illinois Tool Works Inc. (ITW). Other names, logos, icons and marks identifying Instron products and services referenced herein are trademarks of ITW and may not be used without the prior written permission of ITW.

Other product and company names listed are trademarks or trade names of their respective companies.

---

## **Original Instructions**

**Copyright © 2001 Illinois Tool Works Inc. All rights reserved. All of the specifications shown in this document are subject to change without notice.**

---

### **Worldwide Headquarters**

Instron  
825 University Avenue  
Norwood, MA 02062-2643  
United States of America

### **European Headquarters**

Instron  
Coronation Road  
High Wycombe, Bucks HP12 3SY  
United Kingdom

## General Safety Precautions



Materials testing systems are potentially hazardous.

Materials testing involves inherent hazards from high forces, rapid motions, and stored energy. You must be aware of all moving and operating components that are potentially hazardous, particularly the actuator in a servohydraulic testing system or the moving crosshead in an electromechanical testing system.

Whenever you consider that safety is compromised, press the Emergency Stop button to stop the test and isolate the testing system from hydraulic or electrical power.

Carefully read all relevant manuals and observe all Warnings and Cautions. The term Warning is used where a hazard may lead to injury or death. The term Caution is used where a hazard may lead to damage to equipment or to loss of data.

Ensure that the test setup and the actual test you will be using on materials, assemblies, or structures constitute no hazard to yourself or others. Make full use of all mechanical and electronic limits features. These are supplied to enable you to prevent movement of the actuator piston or the moving crosshead beyond desired regions of operation.

The following pages detail various general warnings that you must heed at all times while using materials testing equipment. You will find more specific Warnings and Cautions in the text whenever a potential hazard exists.

Your best safety precautions are to gain a thorough understanding of the equipment by reading your instruction manuals and to always use good judgement.

## Warnings

---

---



### **Hazard - Protect electrical cables from damage and inadvertent disconnection.**

The loss of controlling and feedback signals that can result from a disconnected or damaged cable causes an open loop condition which may drive the actuator or crosshead rapidly to its extremes of motion. Protect all electrical cables, particularly transducer cables, from damage. Never route cables across the floor without protection, nor suspend cables overhead under excessive strain. Use padding to avoid chafing where cables are routed around corners or through wall openings.



### **High/Low Temperature Hazard - Wear protective clothing when handling equipment at extremes of temperature.**

Materials testing is often carried out at non-ambient temperatures using ovens, furnaces, or cryogenic chambers. Extreme temperature means an operating temperature exceeding 60°C (140°F) or below 0°C (32°F). You must use protective clothing, such as gloves, when handling equipment at these temperatures. Display a warning notice concerning low or high temperature operation whenever temperature control equipment is in use. You should note that the hazard from extreme temperature can extend beyond the immediate area of the test.



### **Crush Hazard - Take care when installing or removing a specimen, assembly or structure.**

Installation or removal of a specimen, assembly, or structure involves working inside the hazard area between the grips or fixtures. Keep clear of the jaws of a grip or fixture at all times. Keep clear of the hazard area between the grips or fixtures during actuator or crosshead movement. Ensure that all actuator or crosshead movements necessary for installation or removal are slow and, where possible, at a low force setting.



### **Hazard - Do not place a testing system off-line from computer control without first ensuring that no actuator or crosshead movement will occur upon transfer to manual control.**

The actuator or crosshead will immediately respond to manual control settings when the system is placed off-line from computer control. Before transferring to manual control, make sure that the control settings are such that unexpected actuator or crosshead movement cannot occur.



### **Robotic Motion Hazard - Keep clear of the operating envelope of a robotic device unless the device is de-activated.**

The robot in an automated testing system presents a hazard because its movements are hard to predict. The robot can go instantly from a waiting state to high speed operation in several axes of motion. During system operation, keep away from the operating envelope of the robot. De-activate the robot before entering the envelope for any purpose, such as reloading the specimen magazine.

## Warnings

---

---



**Hazard - Set the appropriate limits before performing loop tuning or running waveforms or test.**

Limits are included in your testing system to limit actuator or crosshead movement. Failure to set these limits appropriately could result in injury to personnel or damage to equipment.



**Electrical Hazard - Disconnect the electrical power supply before removing the covers to electrical equipment.**

Disconnect equipment from the electrical power supply before removing any electrical safety covers or replacing fuses. Do not reconnect the power source while the covers are removed. Refit covers as soon as possible.



**Rotating Machinery Hazard - Disconnect power supplies before removing the covers to rotating machinery.**

Disconnect equipment from all power supplies before removing any cover which gives access to rotating machinery. Do not reconnect any power supply while the covers are removed unless you are specifically instructed to do so in the manual. If the equipment needs to be operated to perform maintenance tasks with the covers removed, ensure that all loose clothing, long hair, etc. is tied back. Refit covers as soon as possible.



**Hazard - Shut down the hydraulic power supply and discharge hydraulic pressure before disconnecting any hydraulic fluid coupling.**

Do not disconnect any hydraulic coupling without first shutting down the hydraulic power supply and discharging stored pressure to zero. Tie down or otherwise secure all pressurized hoses to prevent movement during system operation and to prevent the hose from whipping about in the event of a rupture.



**Hazard - Shut off the supply of compressed gas and discharge residual gas pressure before you disconnect any compressed gas coupling.**

Do not release gas connections without first disconnecting the gas supply and discharging any residual gas pressure to zero.

## Warnings

---

---



**Explosion Hazard - Wear eye protection and use protective shields or screens whenever any possibility exists of a hazard from the failure of a specimen, assembly, or structure under test.**

Wear eye protection and use protective shields or screens whenever a risk of injury to operators and observers exists from the failure of a test specimen, assembly, or structure, particularly where explosive disintegration may occur. Due to the wide range of specimen materials, assemblies, or structures that may be tested, any hazard resulting from the failure of a test specimen, assembly, or structure is entirely the responsibility of the owner and user of the equipment.



**Hazard - Ensure components of the load string are correctly preloaded to minimize the risk of fatigue failure.**

Dynamic systems, especially where load reversals through zero are occurring, are at risk of fatigue cracks developing if components of the load string are not correctly preloaded to one another. Apply the specified torque to all load string fasteners and the correct setting to wedge washers or spiral washers. Visually inspect highly stressed components such as grips and threaded adapters prior to every fatigue test for signs of wear or fatigue damage.

---

## Table of Contents

<b>Chapter 1</b>	<b>Introduction</b> .....	<b>1-1</b>
	Purpose .....	1-2
	Description .....	1-3
<b>Chapter 2</b>	<b>Specifications</b> .....	<b>2-1</b>
	Operational Specifications .....	2-2
<b>Chapter 3</b>	<b>Installation</b> .....	<b>3-1</b>
	Setup Options .....	3-2
	Choosing a Load Cell .....	3-3
	Installation Procedure .....	3-4
<b>Chapter 4</b>	<b>Operation</b> .....	<b>4-1</b>
	Specimen Preparation .....	4-2
	Operating Considerations .....	4-4
<b>Chapter 5</b>	<b>Illustrated Parts</b> .....	<b>5-1</b>
	General .....	5-2
	Parts List .....	5-3

## List of Illustrations

Figure 3-1. Friction Test Fixture Features. . . . .	3-5
Figure 4-1. Specimen Preparation . . . . .	4-3
Figure 5-1. Friction Fixture Component Parts. . . . .	5-4



**List of Tables**

Table 2-1. Operational Specifications. . . . . 2-2  
Table 5-1. Main Assembly Parts. . . . . 5-3

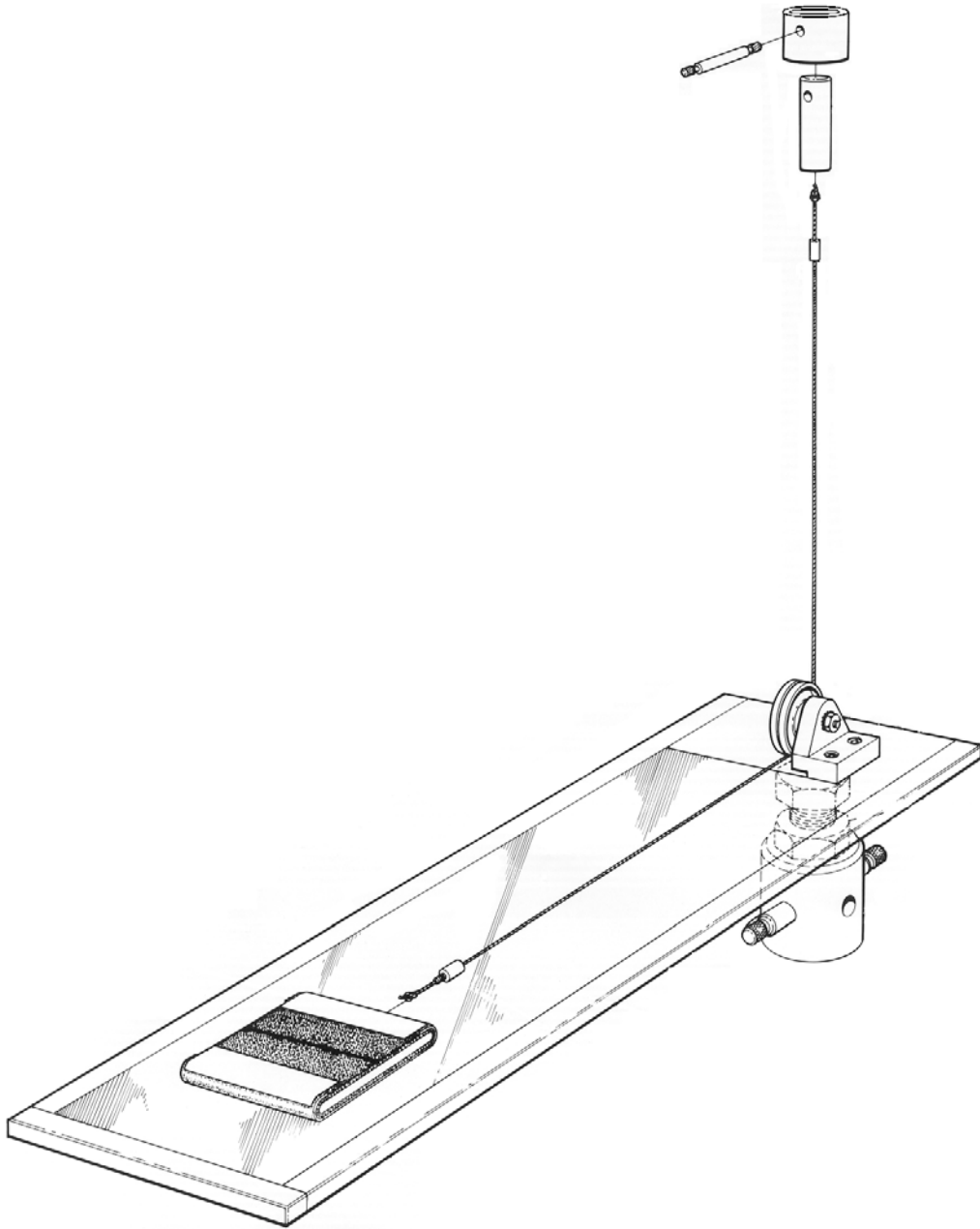

*Instron Model 2810 Coefficient of Friction Testing Fixture*

# Chapter 1 Introduction

## Outline

This chapter introduces you to the Coefficient of Friction Test Fixture and describes its features.

- Purpose..... 1-2
- Description..... 1-3

## Purpose

The Instron Model 2810-005 Coefficient of Friction Test Fixture is a testing device to measure the coefficient of friction between two pieces of a sample material. The fixture mounts in many of Instron's universal test instruments and is driven by that instrument's moving crosshead. In some cases, a load cell coupling may be required to attach the fixture to the load cell.

---

## Description

The Friction Test Fixture consists of a horizontal plate, or table, and a moveable sled. Both the table and the sled are covered with the test material to perform the test. A cord attaches to both the sled and to a load cell, and a pulley guides the cord during the test. The fixture is mounted on the base of the test instrument and, as the crosshead moves, the sled is pulled across the horizontal plate. See Figure 3-1 on page 3-5 for an illustration.

The force to start the sled (static friction) and to keep the sled moving (kinetic friction) are both measured by the load cell, and recorded on a graphical device or stored in a data acquisition system. The acquired force data is divided by the sled weight (200 g) to mathematically determine the static and kinetic coefficient of friction.

Static friction is derived from the first maximum peak (force) on the load curve, and the kinetic friction is derived from an averaged force value between two defined points within the region beyond the first peak on the load curve.

This manual describes how to install the fixture, how to use it, and details the parts that make up the fixture.



# Chapter 2

## Specifications

### Outline

This chapter gives operational specifications for the Coefficient of Friction Test Fixture.

- Operational Specifications . . . . . 2-2

## Operational Specifications

*Table 2-1. Operational Specifications*

Testing area	Testing takes place below the moving crosshead of most test instruments. Provision is made for testing above the moving crosshead on test instruments that have load cells on an upper fixed crosshead.
Load capacity	Determined by load cell used.
Crosshead speed range	Determined by test instrument.
Crosshead speed accuracy	Determined by test instrument.
Friction table material	Aluminum
Surface finish	<32 microinches
Sled weight	200 $\pm$ 2 grams
Sled movement	Approx. 400 mm (16 inches)
Sled size	63.5 mm x 63.5 mm (2.5 in x 2.5 in)
Materials testing standards	ASTM D-1894 and ISO 8295:2004



# Chapter 3 Installation

## Outline

This chapter describes how to set up your Coefficient of Friction Test Fixture. It includes information on choosing a load cell.

- Setup Options . . . . . 3-2
- Choosing a Load Cell . . . . . 3-3
- Installation Procedure . . . . . 3-4



## Setup Options

Typically, the load cell is mounted on the crosshead, and the friction fixture is mounted on the base of the test instrument. The crosshead moves up during the test.

On some test instruments, you can test above the moving crosshead, with the load cell installed in the top fixed crosshead, and the friction fixture mounted on top of the moving crosshead. In this case, the crosshead moves downward.

### Testing to ASTM D-1894

Test using the following:

- Use the white nylon monofilament pull cord.
- Test at a pull rate of 150mm/min

If stick-slip occurs during the kinetic portion of the test, substitute the white nylon monofilament cord with the black multi-filament cord and run a separate test to make the kinetic measurements. Refer to 9.3, Page 4, ASTM D 1894-06 for more details.

### Testing to ISO 8295:2004

Test using the following:

- Use the black multi-filament pull cord and extension spring
- Adjust the testing parameters to achieve a friction drag force of  $2\text{N/cm} \pm 1\text{N/cm}$ .
- Test at a pull rate of 100mm/min. For specialist films or in difficult circumstances, test at 500mm/min; refer to 5.2.3, Page 3, ISO 8294:2004 for more details.

If stick-slip occurs during the kinetic portion of the test, remove the extension spring and run a separate test to make the kinetic measurements.

---

## Choosing a Load Cell

The load cell used for a Coefficient of Friction Test generally is a low-capacity cell, since the forces required to move the friction sled are low. This often means that the normal system load cell must be removed and replaced with a low-capacity cell. If the normal system load cell is a large one, the low-capacity cell can be mounted directly to it without removing the large load cell.

The lower-capacity cells, 1 kg (2 lb), 10 kg (20 lb), or 100 kg (200 lb), provide more accurate test results.

## Installation Procedure

The installation procedure is the same whether the fixture is installed on the cross-head or on the baseplate. Refer to Figure 3-1 on page 3-5 to help identify the various components mentioned in the following procedure.

To install the friction fixture:

1. Install a load cell with a capacity that is consistent with the expected pull force. Refer to “Choosing a Load Cell” on page 3-3 for guidelines on selecting a load cell.
2. Place the friction fixture lower coupling onto the base adapter of the testing instrument. Fit it with the clevis pin and tighten the jam nuts.
3. Attach the hook to the hook adapter. Insert the hook adapter into the load cell (or load cell coupling), and insert the clevis pin.

*Note:* A load cell coupling may be required if the hook adapter is not compatible with the load cell connection. Contact your Instron sales representative for more information.

4. Slip the loop on one end of the pull cord over the hook that is connected to the load cell (or load cell coupling). Slip the loop on the other end of the cord over the friction sled hook.
5. Ensure that the pulley spins freely without rubbing. If it rubs, adjust the pulley support until the pulley no longer rubs, and then tighten the pulley support screws.
6. Arrange the cord around the pulley so that it sits in the groove on the pulley.
7. Position the moving crosshead (use the test instrument **JOG** controls) so there is sufficient travel space to draw the friction sled along the full length of the friction table. Keep the cord taut while the crosshead is moving.
8. Set the gauge length and extension controls on the test instrument in order to set travel limits. This prevents the friction sled from colliding with the pulley during the test.

The test fixture is now ready for testing.

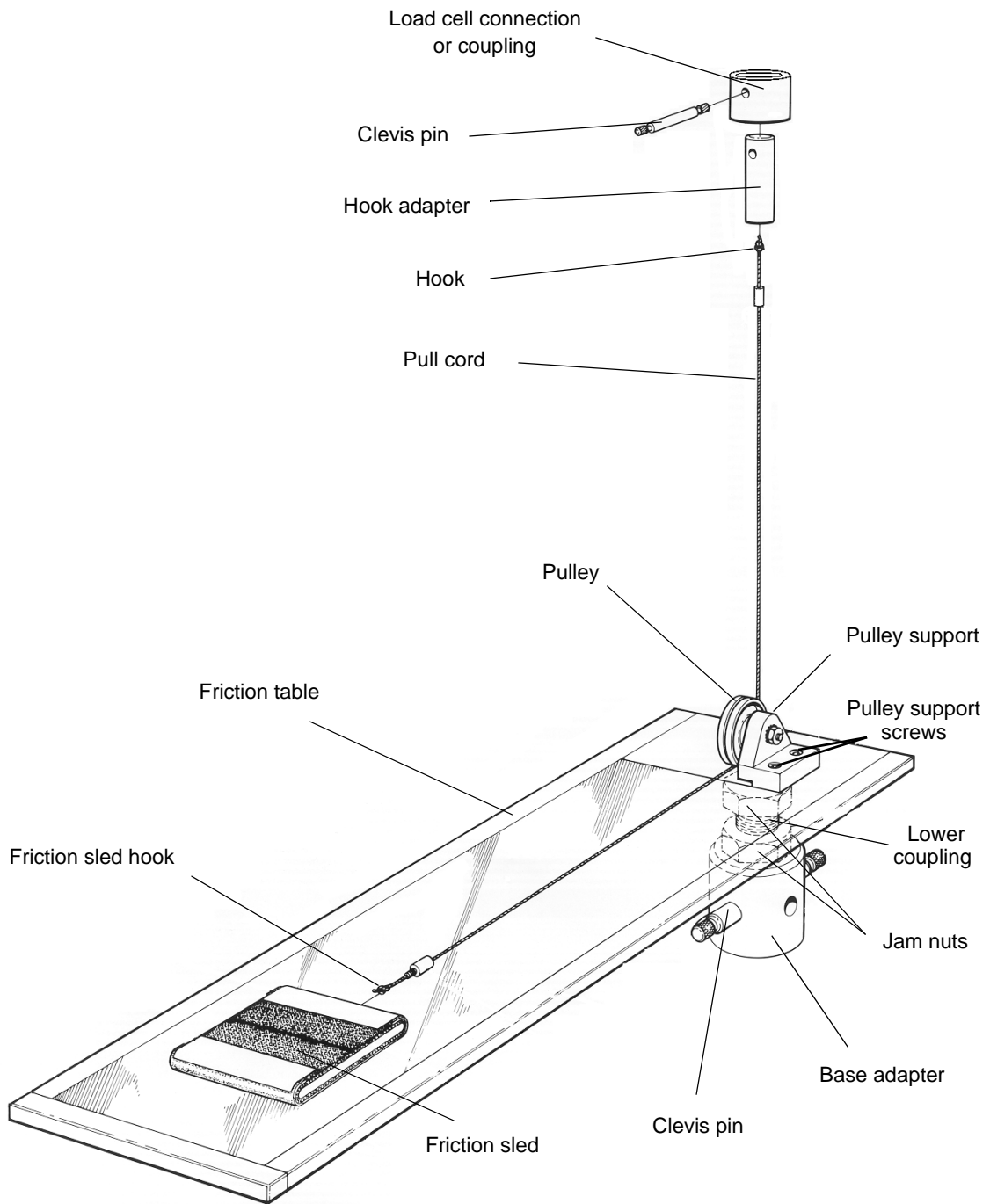

Figure 3-1. Friction Test Fixture Features



# Chapter 4 Operation

## Outline

Operation of the Coefficient of Friction Test Fixture involves two main steps: preparation of the specimen, and running the test. The following sections describe these steps.

- Specimen Preparation ..... 4-2
- Operating Considerations..... 4-4



## Specimen Preparation

To test the coefficient of friction of a material, two pieces of the material are rubbed against each other and the force required to move one piece against the other is measured. Proper preparation of the specimen is critical to the successful and accurate measurement of this force.

Refer to Figure 4-1 on page 4-3 to help identify the various components mentioned in the following procedure.

To prepare the specimen:

1. Cut a piece of the specimen material large enough to cover the friction sled and to overlap it on opposite sides.

*Note:* Avoid touching the specimen's testing surface since this may alter the specimen surface and affect your results.

2. Tape one edge of the material securely to the top of the sled. Stretch the material taut across the face of the sled, eliminating all bulges and wrinkles. While holding the material taut, tape the opposite edge to the top of the sled.
3. Cut a second piece of the material large enough to cover the friction table. This piece does not have to overlap the sides of the table.
4. Tape this second piece of material to the friction table. Again, be sure there are no bulges or wrinkles. This material must lie absolutely flat against the table.
5. Attach the sled to the pull cord and place the sled very lightly and gently on the friction table in order to prevent any unnatural bond from developing between the two specimens. Inspect the sled to be sure no tape touches the table when the sled is placed in position.



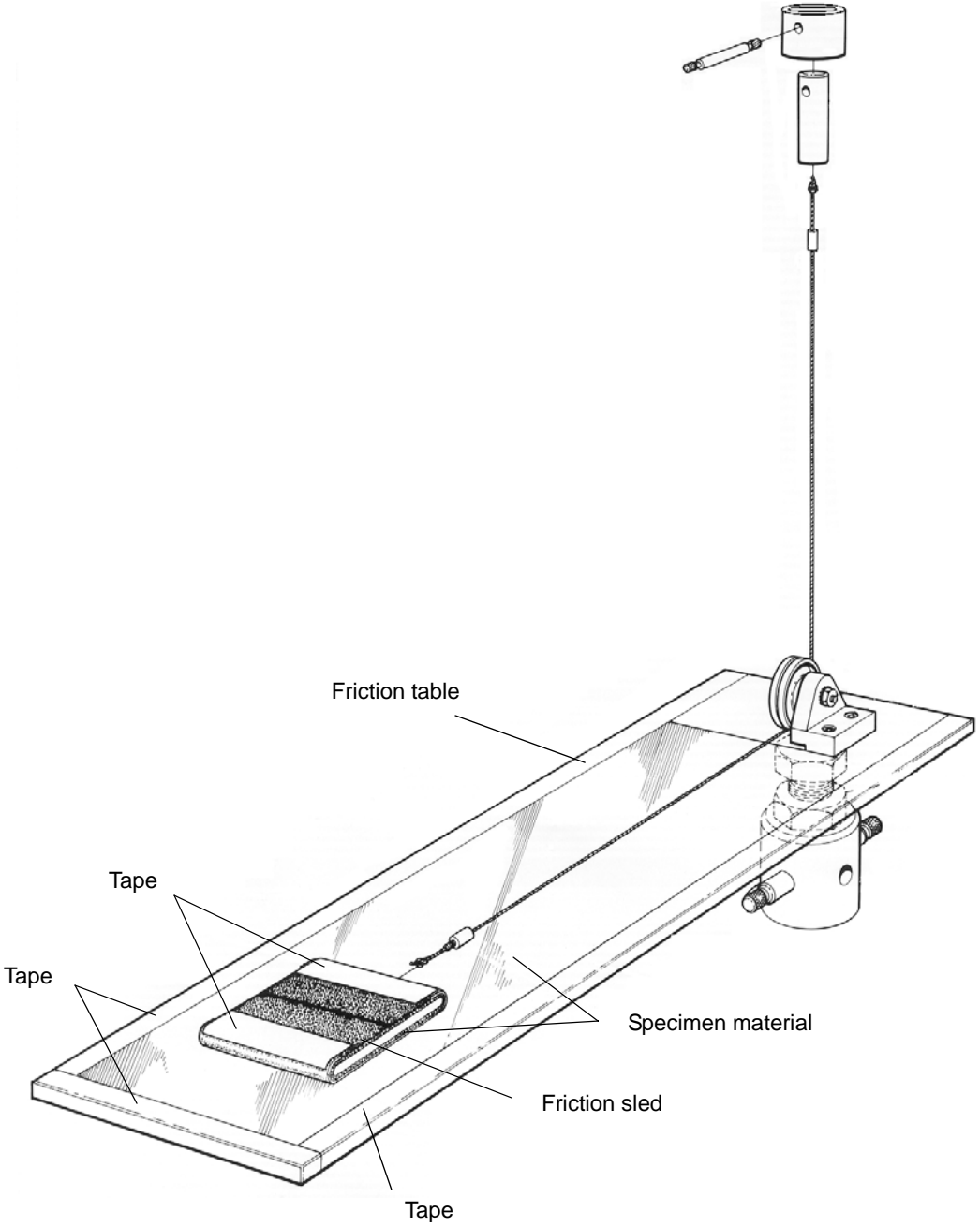

Operation

Figure 4-1. Specimen Preparation

## Operating Considerations

The Friction Test Fixture is designed to conform to the requirements of ASTM Standard D-1894. Thus, the operating procedure is dictated by the requirements of the ASTM standard. The following points, however, should be considered when setting up and running tests:

- Make sure the pull cord is taut before the start of the test. Any slack in the cord causes erroneous test results.
- Before the start of the test, raise (or lower, depending on the direction of the crosshead) the crosshead far enough so that the friction sled reaches the outer end of the friction table with the cord taut. This ensures that there is enough space to pull the sled the full distance required by the test standard.
- Set crosshead travel limits so that the sled does not collide with the pulley at the end of the test run. If the sled or the loop in the cord strikes the pulley, the test results will be impaired.

# Chapter 5

## Illustrated Parts

### Outline

This chapter provides an illustration and listing of parts that make up the Coefficient of Friction Test Fixture. It can be used for identifying parts or for ordering replacements parts.

- General ..... 5-2
- Parts List ..... 5-3

## General

This chapter provides illustrations and listings of the Model 2810-005 Coefficient of Friction Test Fixture component parts to facilitate ordering replacement parts and for general reference. To identify the various components, first locate the part in Figure 5-1 on page 5-4 and then refer to its item number in the associated table.

To understand data given in the tables, note the following:

- The Item Number column indicates the callout number from Figure 5-1.
- The Part Number column lists only Instron part numbers.
- The Description column includes the common name of an item and other terms relating to its usage. The description may also list the manufacturer's part number when appropriate.
- The Quantity column provides how many of that part is required. Quantities for similar parts used elsewhere are in separate listings.

*Note: When ordering parts from Instron, specify the part number, description, and the quantity of the parts you need. Also, supply your testing system type and its serial number in order to assist Instron in confirming the configuration of your testing system.*

# Parts List

Table 5-1. Main Assembly Parts

Item Number	Part Number	Description	Quantity
1	T53-8	Friction table	1
2	T53-2	Pulley support	1
3	T53-1	Pulley	1
4	4-1-2	Bearing ball	2
5	T53-3	Pulley spacer	1
6	201G33	Screw, cap, socket head 8-32 x 1/2 inch	2
7	201H46	Screw, cap, socket head 10-32 x 1 inch	1
8	600B6	Nut, 10-32	1
9	T53-9	Fitting, crosshead adapter (lower coupling)	1
10	602F10	Nut, jam, 1-14	2
11	101-1-2	Tow line, Sevalon	4 m (13.124 ft)
	101-1-10	Tow line, nylon	4 m (13.124 ft)
12	A53-6	Friction sled assembly	1
13	A53-5	Screw & hook assembly for friction sled	1
14	T53-14	Hook, tow line	1
15	T53-15	Adapter, Type C coupling (Hook adapter)	1
	T53-16	Adapter, Type B coupling	1
	T53-17	Adapter, Type O coupling	1

**Note:** A load cell coupling may be required if the hook adapter is not compatible with the load cell connection. Contact your Instron sales representative for more information.

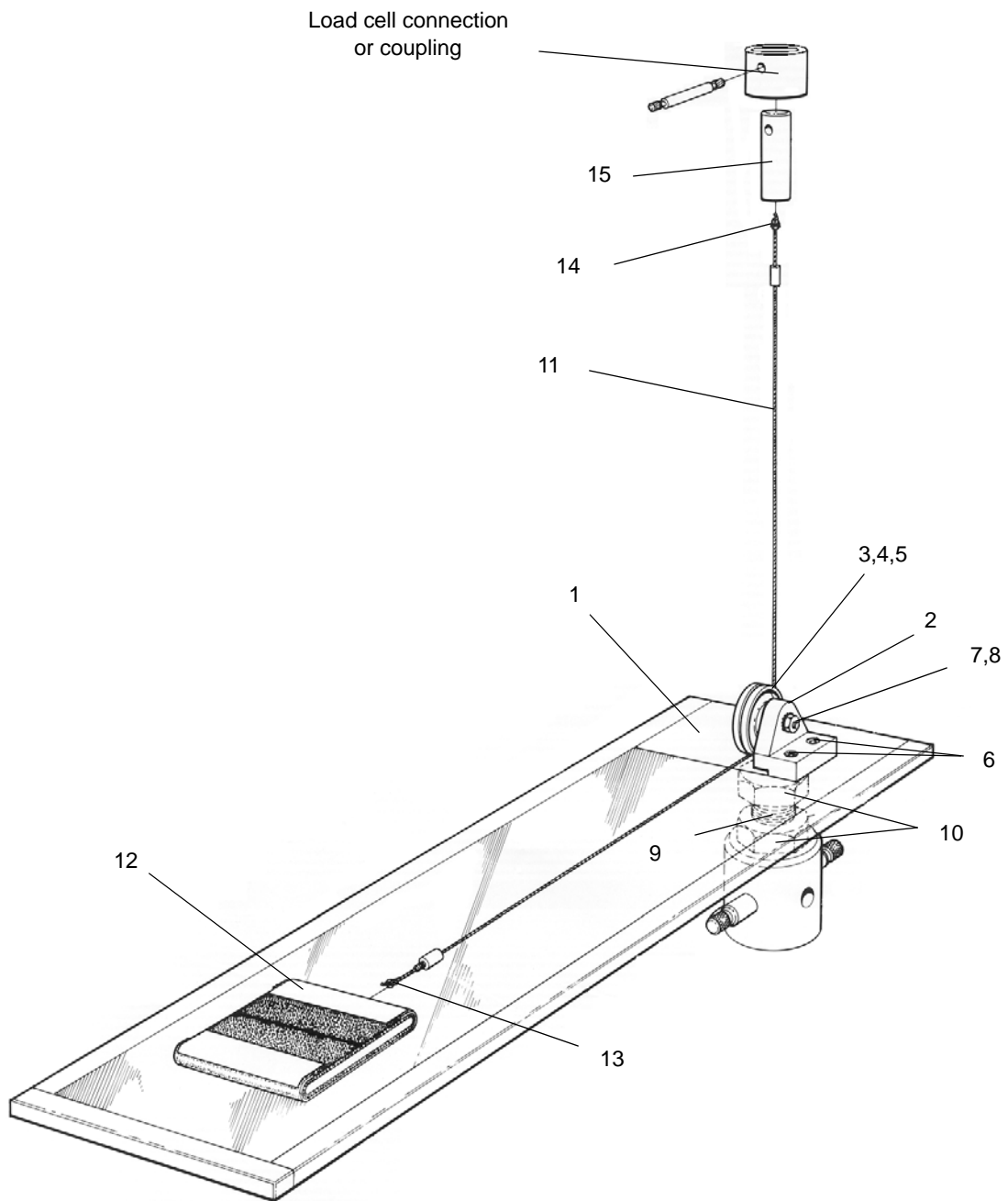

Figure 5-1. Friction Fixture Component Parts





Product Support: [www.instron.com](http://www.instron.com)