

1 kN HIGH-TEMPERATURE PNEUMATIC ACTION GRIPS

2732 SERIES 2732-008, 2732-009

High-temperature pneumatic action grips provide a convenient method for clamping delicate films, polymers, and woven fabrics within a temperature controlled environment. The grips are made of 300 Series stainless steel to prevent rusting caused by condensing air when testing with a cooling cycle. Interchangeable grip faces are available in various sizes and surfaces including smooth ground, rubber coated, serrated, line-contact, and special coated. A variety of pull rods are also available to accommodate different specimens and optimize load string space.

High-temperature pneumatic action grips are activated automatically or by a foot switch, allowing the operator free use of their hands. Clamping forces are selectable to accommodate a wide range of material types. Jaw faces automatically adjust to specimen thickness to ensure that the line of tensile force remains concentric with the grip body. The grips automatically compensate for specimen creep, maintaining an appropriate holding force throughout the test.

FEATURES AND BENEFITS

- Rated capacity: 1 kN (100 kgf, 225 lbf)
- Open front design to facilitate specimen loading
- Self-centering action allows different specimen thickness without adjustment
- Pneumatic clamping of the specimen with follow-up action to reduce slippage
- Rugged design for minimum maintenance
- Adjustable gripping control
- Interchangeable jaw faces suitable for gripping different types of materials
- Rectangular jaw faces may be mounted with the long axis either horizontal or vertical to accommodate various specimens
- Temperature range: -70 °C to +315 °C (-100 °F to +600 °F)
- Optional automatic air kit with pretension and remote control for easy loading and improved efficiency
- Upper & Lower grips can be closed/opened independently
- 2 Wheels make maneuvering simple
- Quiet operation minimizes operator discomfort - Less than 65 dB at full pressure
- 3 µm Filter - Preventing damage to pump or grip components from dirt/debris
- Easily visible sight glass to check oil level & condition

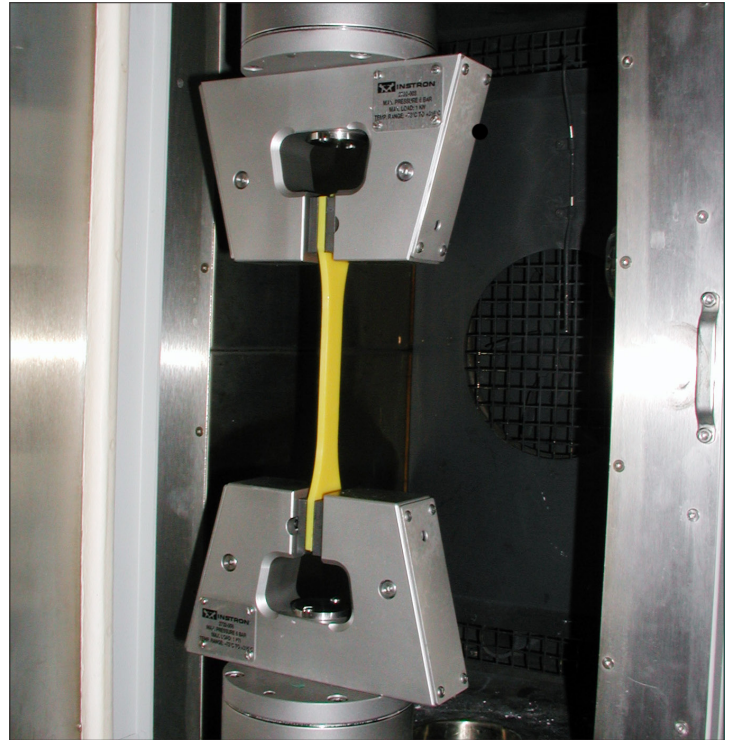

APPLICATION RANGE

- Type of loading: Tension
 - *Not suitable for through zero/reverse stress or fatigue testing
- Specimen material: Thin sheets, films, foils, threads, plastic tapes, fine wires and soft materials
- Specimen shapes: Round (wires) and flat specimen with/without shoulder tab ends

PRINCIPLE OF OPERATION

Pneumatic action grips clamp the specimen by using a dual lever arm actuated by air cylinders built into the grip body. The air cylinders are connected to pull rod extensions for fitting inside the temperature chamber. The air input to the grips passes through the hollow pull rods via a connection outside of the chamber. The gripping force can be increased with air pressure to accommodate materials that are often difficult to hold. This constant gripping force is maintained on the specimen and provides the ultimate in follow-up action to compensate for any decay in the gripping force as the test proceeds. The grips may be closed or opened by a pneumatic footswitch for hands-free operation. An automated air kit is also available for hands-free, automated, and pre-tension testing. The interchangeable jaw faces are held on the grip in a manner that one face is free to swivel on a horizontal axis and the other on a vertical axis. This action allows for self-alignment to compensate for variations in sample thickness.

SPECIFICATIONS

		2732-008	2732-009
Maximum Capacity	kg	100	100
	kN	1	1
	lb	225	225
Connection upper		Pneumatic connection	Pneumatic connection
Connection lower		Pneumatic connection	Pneumatic connection
Overall Width (A)	mm	145	153
	in	5.7	6.0
Effective length upper	mm	193	193
	in	7.6	7.6
Effective length lower	mm	193	193
	in	7.6	7.6
Throat Depth (C)	mm	38	38
	in	1.5	1.5
Throat Depth (D)	mm	16	16
	in	0.6	0.6
Weight Per Grip	kg	4.1	4.2
	lb	9.0	9.2
Temperature Range	°C	-73 to +316	-73 to +316
	°F	-100 to 600	-100 to 600
Clamping Force	kN	4.98	2.5
	kgf	498	250
	lbf	1120	560
Maximum Air Pressure	bar	6.3	6.3
	PSI	90	90
Specimen Thickness	mm	0 to 6.3	12.7
	in	0 to 0.25	0 to 0.5

Notes:

- Grip catalog provides two grips
- Grips require upper and lower pneumatic pull rods to connect to the load cell and machine base
- Upper grip may require a flexible coupling for certain applications
- Automatic air control kit or pneumatic footswitch will be required for operation of these grips

PULL RODS

Catalog Number	Description	Unit of Measure	Effective Length		Mechanical Fitting
			kN	mm in	
3119-305	Lower pullrod	10	81	3.2	Pneumatic connection to 1/2 in clevis pin (Type Dm)
3119-306	Lower pullrod	10	118	4.6	Pneumatic connection to 1/2 in clevis pin (Type Dm)
3119-311	Lower pullrod	10	160	6.3	Pneumatic connection to 1/2 in clevis pin (Type Dm)
3119-318	Lower pullrod	-	316	12.4	Type Om (12 mm connection with 6 mm Clevis pin) to Pneumatic Connection
3119-319	Lower pullrod	-	380	15.0	Type Om (12 mm connection with 6 mm Clevis pin) to Pneumatic Connection

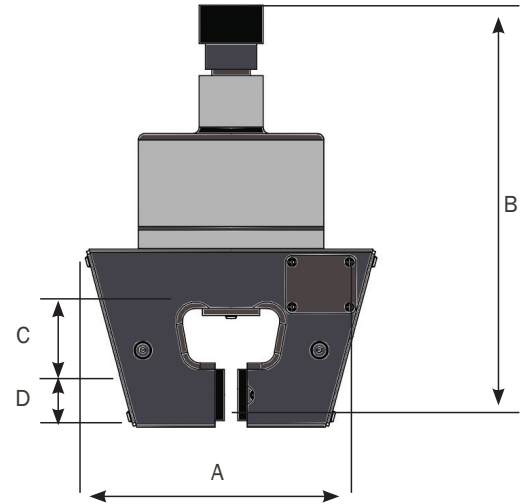

Grip Dimensions



Upper and Lower Pneumatic Pull Rods

ACCESSORIES

2810-060	Air compressor, portable 240V, European Plug
2701-004	Pneumatic footswitch
2701-065	Automatic air control kit for 4400, 5500 (excluding 4411 and upgrade (excluding 1130, 6000, 4500 and TTs)

Notes:

1. Faces catalog number provides four faces
2. All faces are hardened to 60 - 65 Rc, excluding rubber-coated and if otherwise specified
3. Line contact faces are provided with a smooth ground opposing face
4. The width and height of the faces are interchangeable, providing that one half of the vertical dimension of the faces less than dimension C
5. All rubber-coated faces are limited to a temperature range of -20 °C to +115 °C

JAW FACES

Catalog Number	Clamping Area (W × H)		Surface	Application
	mm	in		
2702-011	12 × 38	0.5 × 1.5	Smooth ground	For gripping thin sheets, films, foils, paper and tapes
2702-031	25 × 25	1 × 1	Smooth ground	For gripping thin sheets, films, foils, paper and tapes
2702-014	25 × 38	1 × 1.5	Smooth ground	For gripping thin sheets, films, foils, paper and tapes
2702-017	50 × 38	2 × 1.5	Smooth ground	For gripping thin sheets, films, foils, paper and tapes
2702-034	76 × 25	3 × 1	Smooth ground	For gripping thin sheets, films, foils, paper and tapes
2702-012	12 × 38	0.5 × 1.5	Rubber-coated	For gripping threads, fabrics, plastic tapes and fine wires
2702-032	25 × 25	1 × 1	Rubber-coated	For gripping threads, fabrics, plastic tapes and fine wires
2702-015	25 × 38	1 × 1.5	Rubber-coated	For gripping threads, fabrics, plastic tapes and fine wires
2702-018	50 × 38	2 × 1.5	Rubber-coated	For gripping threads, fabrics, plastic tapes and fine wires
2702-035	76 × 25	3 × 1	Rubber-coated	For gripping threads, fabrics, plastic tapes and fine wires
2702-013	12 × 38	0.5 × 1.5	Diamond-serrated, pitch 1 mm (25-teeth per in)	For gripping plastic and soft materials
2702-033	25 × 25	1 × 1	Diamond-serrated, pitch 1 mm (25-teeth per in)	For gripping plastic and soft materials
2702-016	25 × 38	1 × 1.5	Diamond-serrated, pitch 1 mm (25-teeth per in)	For gripping plastic and soft materials
2702-019	50 × 38	2 × 1.5	Diamond-serrated, pitch 1 mm (25-teeth per in)	For gripping plastic and soft materials
2702-059	76 × 25	3 × 1	Diamond-serrated, pitch 1 mm (25-teeth per in)	For gripping plastic and soft materials
2702-020	25 × 2.3	1 × 0.09	Line contact 3	For gripping elasticated fabrics, paper and rigid plastic films
2702-062	76 × 2.3	3 × 0.09	Line contact 3	For gripping elasticated fabrics, paper and rigid plastic films
2702-044	25 × 38	1 × 1.5	High friction compound	For gripping bundled reinforced plastics and other materials at elevated temperatures
2702-045	50 × 38	2 × 1.5	Waved profile	For gripping fabrics and plastic tape

www.instron.com

Worldwide Headquarters
825 University Ave, Norwood, MA 02062-2643, USA
Tel: +1 800 564 8378 or +1 781 575 5000

European Headquarters
Coronation Road, High Wycombe, Bucks HP12 3SY, UK
Tel: +44 1494 464646